

## DEPOSIT STRESS ANALYZER PLATING CELL – PN 785

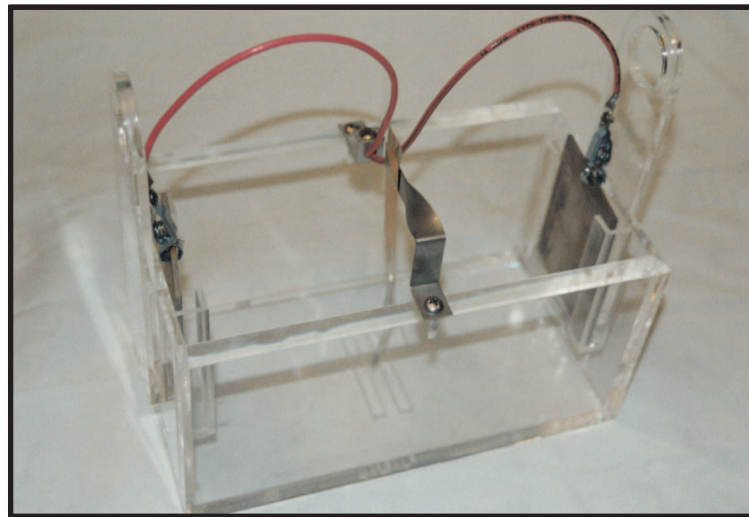

The PN 785 Plating Cell is specifically designed for precision deposit stress measurements. It is amenable to both the working tank or a lab table top. The cell offers a standard geometry with respect to anode size and positioning. Consistent anode to cathode spacing is maintained.

The cell consists of the following features:

- Handles for holding the cell in the plating bath
- Two anode pockets for 2" x 2" anodes (Anodes not available through Specialty Testing)
- Leads to each anode from a centrally located contact
- A clip assemble for positioning the test strip midway between the anodes
- Solution ports for electrolyte to enter and exit the cell
- All Lucite construction

For working at a laboratory bench, a one gallon polypropylene container, PN, 100 is available. A maximum temperature of 200°F can be used to hold the electrolyte sample in which the PN 785 Plating Cell is positioned for test strip plating.

## IN-SITE 1 Plating Cell for In-Tank Deposit Stress Analysis

**In-Site 1** is the first and only stress measurement cell small enough to be permanently mounted in your tank and allow direct stress monitoring during the plating cycle. No additional anodes are required. Use the tank anode for your plating test. Featuring compact design, in-tank positioning and free solution circulation, **In-Site 1** gives you the most accurate and consistent stress readings possible. Simply use the same current density your parts are being plated at. **In-Site 1** is designed to be used in conjunction with the **Deposit Stress Analyzer** (PN: 683).

Now you can maintain true low-stress conditions in your tanks by making additions based on accurate, real-time in-tank stress measurements.

**To carry out a stress test:** Mount the bracket to the tank lip in an accessible area with adequate electrolyte circulation, as shown in the above drawing. Attach the cell to the bracket, making sure solution will cover the uncoated legs of a test strip inserted in it. The cell can be left in the tank permanently for ease of future testing. Connect it to the tank's power supply outputs or the anode and cathode bars in the working tank.

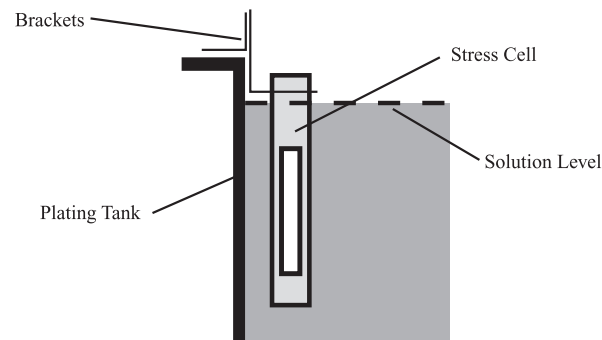

Insert a new cleaned test strip into the stress-cell through its wider top opening and clamp the strip to the center rib in the opening with the negative output clip. The test strip leg tips must be on the inside of the cell, equally exposed to the open ports. Set the appropriate current value. Plate for the amount of time required (see instructions for the Deposit Stress Analyzer). After the end of the plating cycle, determine deposit stress with the Deposit Stress Analyzer and the formula as given in the brochure.

### In-Site Specifications

Dimensions, in. (mm)..... 1-1/8(29) O.D. x 6-1/2(165)  
 Operating temperature ..... up to 170 °F

# DEPOSIT STRESS ANALYZER

*Prevent Deposit Flaking Before It Occurs*

A STRESS MEASUREMENT METHOD

APPLICABLE FOR THIN COATINGS

*Metallic — Organic Resists and Lacquers — Baked Ceramic Layers*



PN 683  
 Deposit  
 Stress  
 Analyzer

ECONOMICAL TO USE

RAPID DETERMINATIONS

ACCURATE RESULTS

DISCARDABLE TEST STRIPS

SMALL SAMPLE SURFACE AREA

SMALL ELECTROLYTE VOLUME

NO EQUIPMENT CALIBRATION

\* Patent Pending

**SPECIALTY TESTING & DEVELOPMENT CO.**

P.O. BOX 126 • JACOBUS, PENNSYLVANIA 17407 • USA

PHONE (717) 428-0186 • FAX (717) 428-0294

[www.specialtytest.com](http://www.specialtytest.com)

# DEPOSIT STRESS ANALYZER SYSTEM

## 1. EQUIPMENT DESCRIPTION

The Deposit Stress Analyzer System is comprised of an economical, disposable Test Strip, PN 785 Plating Cell, and PN 683 Test Stand. The Test Strip has a small surface area and can be plated in the work tank or in a laboratory setting using the Plating Cell. The Cell offers a standard anode to cathode spacing to ensure uniform current density across the Test Strip legs. After plating, the Test Strip is supported in the Test Stand which measures in increments the distance that the Test Strip legs have spread. The distance is included in a formula which calculates the deposit stress in pounds per square inch. Stress is also determined to be compressive or tensile in nature. Small permanently mountable plating cells (PN 492) are also available.

The measuring device supports the plated test strip over the scale so the number of scale increments between the tips of the test piece can be read. The increment reading can then be included in a formula to calculate the internal deposit stress in pounds per square inch.

## 2. TEST PROCEDURE

Activate using a mild non-alkaline soak cleaner, water rinse, immerse in 10% sulfuric acid for 30 seconds, and water rinse.

Best results are obtained with a plating set up similar to the photograph on page 4. Anodes should be located at least three inches away from the test strip and should be positioned in a parallel plane with the test strip. Electrical contact should be made at the top of the test strip where there is a void in the masking material. Do not plate this void.

The plating current density should be adjusted with a given electrolyte so as not to cause deposit burning at the test strip tips, yet sufficient enough to conduct a rapid test. Preferably, the current density should be maintained at the approximate value at which the bath is normally worked.

The plating test should be continued until the test strip legs deflect from 1-2 centimeters for the most accurate results. The required plating time can be determined experimentally by examining the degree of spread after each minute of plating.

## 3. CALCULATIONS

If the test strip legs are spread outward on the side that has been plated (plated side out and resist side in) the deposit stress is tensile in nature. If the test strip legs are spread inward on the side that has been plated, the deposit stress is compressive in nature.

It is necessary to know both the combined units or increments of spread of each leg from the center line on the measuring block scale and the deposit thickness in order to calculate the deposit stress. If the deposit thickness cannot be determined by actual measurement, it can be calculated as follows:

$$T = \frac{W}{D \times A} \times .394 \text{ inch/cm}$$

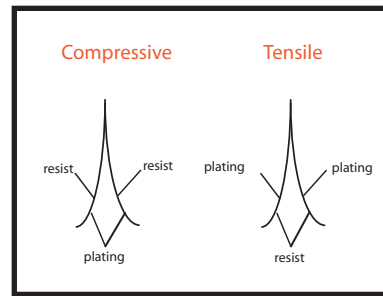

where T = deposit thickness in inches, W = deposit weight in grams, D = specific gravity of the deposited metal in grams per cubic centimeter and A = surface area in square centimeters. Since the plated surface area on a test strip is 7.74 square centimeters, the formula for deposit thickness can be shortened as follows:

$$T = \frac{W}{D} \times .0509$$

For example, if determining the thickness of a nickel deposit that weighed .0349 grams, the calculation would become:

$$T = \frac{.0349}{8.90} \times .0509 = .000200 \text{ inch}$$

After the deposit thickness is known and the number of increments spread between the test strip leg tips has been determined, the deposit stress can be calculated thus:

$$S = \frac{U}{3T} \times K$$

where S = pounds per square inch, U = number of increments spread, T = deposit thickness in inches, and K is the strip calibration constant.

It is recognized that each lot of test strips manufactured will respond with slight differences when used for deposit stress tests. This degree of difference will be determined by the supplier when each lot of test strips is calibrated. The value for K will be supplied with each lot of test strips shipped. Thus, calibration during use on the field is not necessary.

## 4. TABLE OF DENSITY VALUES (GRAMS/CUBIC CENTIMETER)

| Deposited Metal | Density |
|-----------------|---------|
| Cadmium         | 8.65    |
| Chromium        | 7.19    |
| Copper          | 8.96    |
| Gold (Soft)     | 19.45   |
| Gold (Hard)     | 17.60   |
| Nickel          | 8.90    |
| Palladium       | 12.00   |
| Platinum        | 21.45   |
| Rhodium         | 12.44   |
| Ruthenium       | 12.20   |
| Silver          | 10.49   |
| Tin             | 7.30    |
| Zinc            | 7.13    |

## 5. TEST STRIPS

The test strips are made from chemically etched copper alloy or steel and have spring like properties. Thus, even if the test strip legs are accidentally moved prior to reading the increments spread, they will return to the correct position so a reading can be obtained.

Test strips are available for all acidic and alkaline plating chemistries.

PN 1194 Test Strips made from Copper 194 material (can use a Wood's nickel strike of several micro inches thickness to activate copper alloy strips for electroless nickel plating).

PN 2042B Super Sensitive Test Strips made from Alloy 42 steel material 0.0015 inch thick for very low stress value measurements (self-activate in most electroless plating baths).

### Test For Nickel (100m inches)

| ASF | AMPERES | TIME           |
|-----|---------|----------------|
| 10  | .083    | 12 minutes     |
| 20  | .167    | 6 minutes      |
| 25  | .208    | 4 min. 48 sec. |
| 50  | .416    | 2 min. 24 sec. |

PN: 3194 Test Strips made from Copper 194 material. These strips have no masking material and are sold in lots of 25 pcs. for \$2.50 each. These strips have application for thin organic coatings including resists and lacquers, and thin ceramic coatings. Simply apply the coating on opposite sides of the test strip legs uniformly and cure or bake.

## 6. APPROXIMATE PLATING RATES ON TEST STRIPS FOR THE COMMON ELECTROLYTES

| Electrolyte  | % Efficiency | Amps | ASF | Microinches / Minute |
|--------------|--------------|------|-----|----------------------|
| Cadmium      | 100          | .33  | 40  | 27.5                 |
| Chromium     | 20           | 2.90 | 350 | 10.0                 |
| Copper (ous) | 100          | .16  | 20  | 38.5                 |
| Copper (ic)  | 100          | .33  | 40  | 37.0                 |
| Gold (Soft)  | 100          | .08  | 10  | 28.0                 |
| Gold (Hard)  | 40           | .33  | 40  | 44.5                 |
| Nickel       | 100          | .83  | 100 | 83.5                 |
| Palladium    | 90           | .25  | 30  | 35.5                 |
| Silver       | 100          | .16  | 20  | 60.0                 |
| Tin (ous)    | 100          | .42  | 50  | 110.0                |

PN: 683 Deposit Stress Analyzer

PN: 785 Plating Cell

PN: 100 Electrolyte Contain

PN: 492 In-Site Plating Cell

All prices are in US funds -- payable by US drawn check, Master Card or Visa, or bank wire transfer.